

CHANNEL VISION  
Limited Warranty

Channel Vision Technology will repair or replace any defect in material or workmanship which occurs during normal use of this product with new or rebuilt parts, free of charge in the USA, for two years from the date of original purchase. This is a no hassle warranty with no mail in warranty card needed. This warranty does not cover damages in shipment, failures caused by other products not supplied by Channel Vision Technology, or failures due to accident, misuse, abuse, or alteration of the equipment. This warranty is extended only to the original purchaser, and a purchase receipt, invoice, or other proof of original purchase date will be required before warranty repairs are provided.

Mail in service can be obtained during the warranty period by calling (800) 840-0288 toll free. A Return Authorization number must be obtained in advance and can be marked on the outside of the shipping carton.

This warranty gives you specific legal rights and you may have other rights (which vary from state to state). If a problem with this product develops during or after the warranty period, please contact Channel Vision Technology, your dealer or any factory-authorized service center.

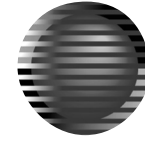

CHANNEL VISION<sup>TM</sup>  
*Central*

C-1158 (SAT-HD58)

HDTV Multiswitch

CHANNEL VISION<sup>TM</sup>

234 Fischer Avenue · Costa Mesa, CA 92626  
(714) 424-6500 · (800) 840-0288 · (714) 424-6510 fax  
www.channelvision.com · email: sales @ channelvision.com

© 2004, Channel Vision<sup>TM</sup>

## Model C-1158 (Sat-HD58) Features/Instructions:

- Install four coax runs from the dish to the C-1158. Connect the outputs of LNB 101 to inputs A and B and the outputs of LNB 119 to inputs C and D. Note: the existing 4x4 multiswitch must be removed. (Figure 1)
- When installing a new High Definition Dish with an integrated multiswitch, all four outputs of the dish are the same. Connected any two of the four outputs directly to inputs A and B, then install the two 22 kHz tone generators in-line with the remaining two outputs. Use short coax jumpers to connect the output of the tone generators to inputs C and D of the C-1158. (Figure 3)
- When connecting a local Antenna/CATV feed to the Terr. (Terrestrial) input on the bottom of the C-1158, a diplexer will be needed at each TV to separate the Satellite and Terrestrial signals. (Figure 1)

**Wiring:** Use RG-6 for typical installs. Long runs may require RG-11.

DUO DISH LNB 119/LNB 101 **Figure 1**

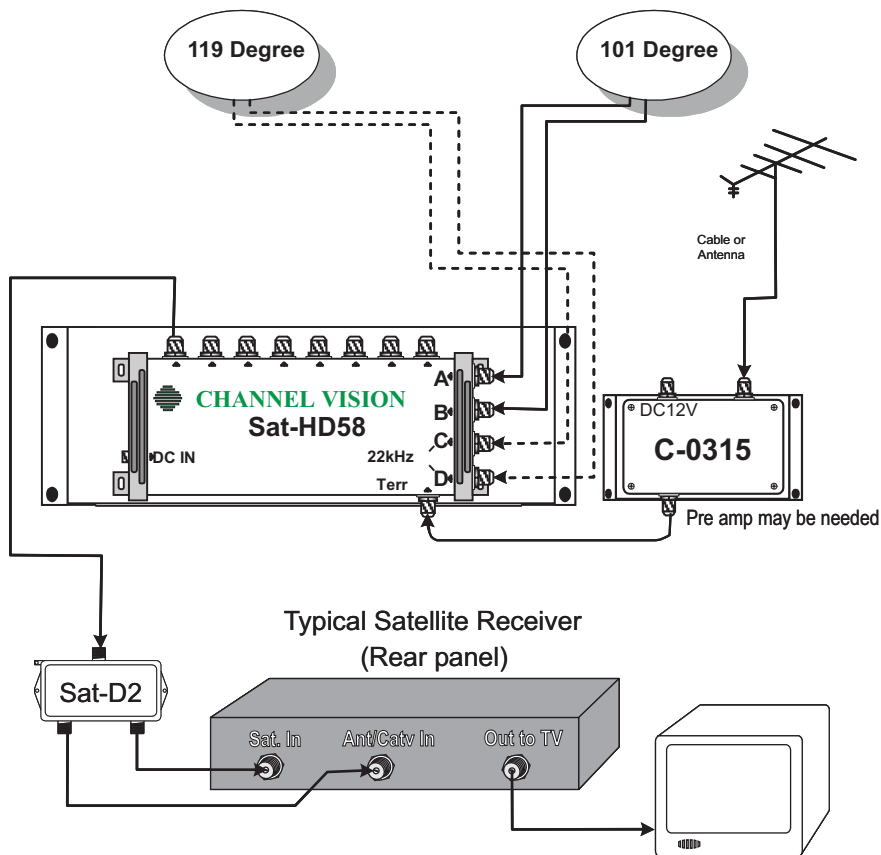

C-KIT 110 upgrade  
(for existing Direct Plus dish)

**Figure 2**

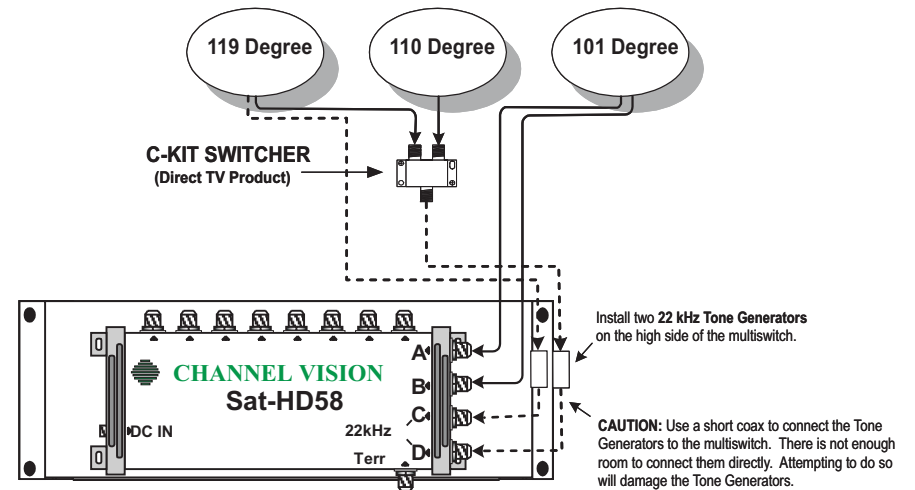

Note: When the 110 LNB is added to the Direct TV Dish, you must add two 22 kHz Tone Generators (Channel Vision Part # SAT-22T) to the high side of the SAT-HD58 (port C/D)

The New 5x4 Integrated  
Switch/Dish by RCA

**Figure 3**

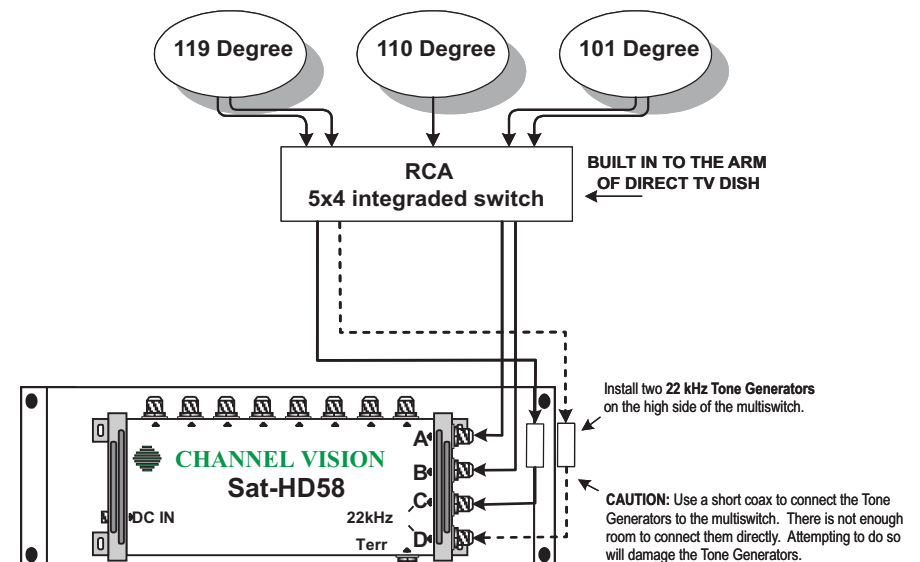

The Tone Generators that are included with this multiswitch can be purchased separately as Channel Vision part # Sat-22T